

# ZG-1058 Pendant Luminaires

---





## HEAT DISSIPATION PERFORMANCE

Advanced FEA technology designs for the structure thermal transfer to guarantee the LED PCB and chips can use for long life.

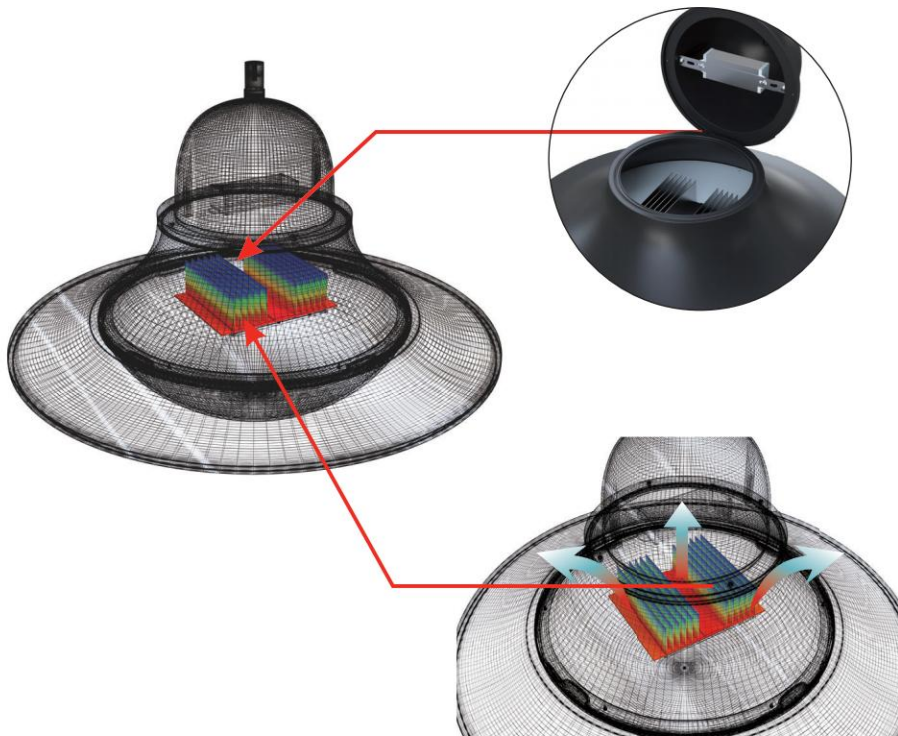

Non-contact structure for LED drivers and heat sinks. The electrical parts are in cool status.

Stretching aluminum heat sinker is designed inside. The air convection structure enhances the lumen maintenance performance.

## **THERMAL- ELECTRICAL DIVIDED**

Product Overview

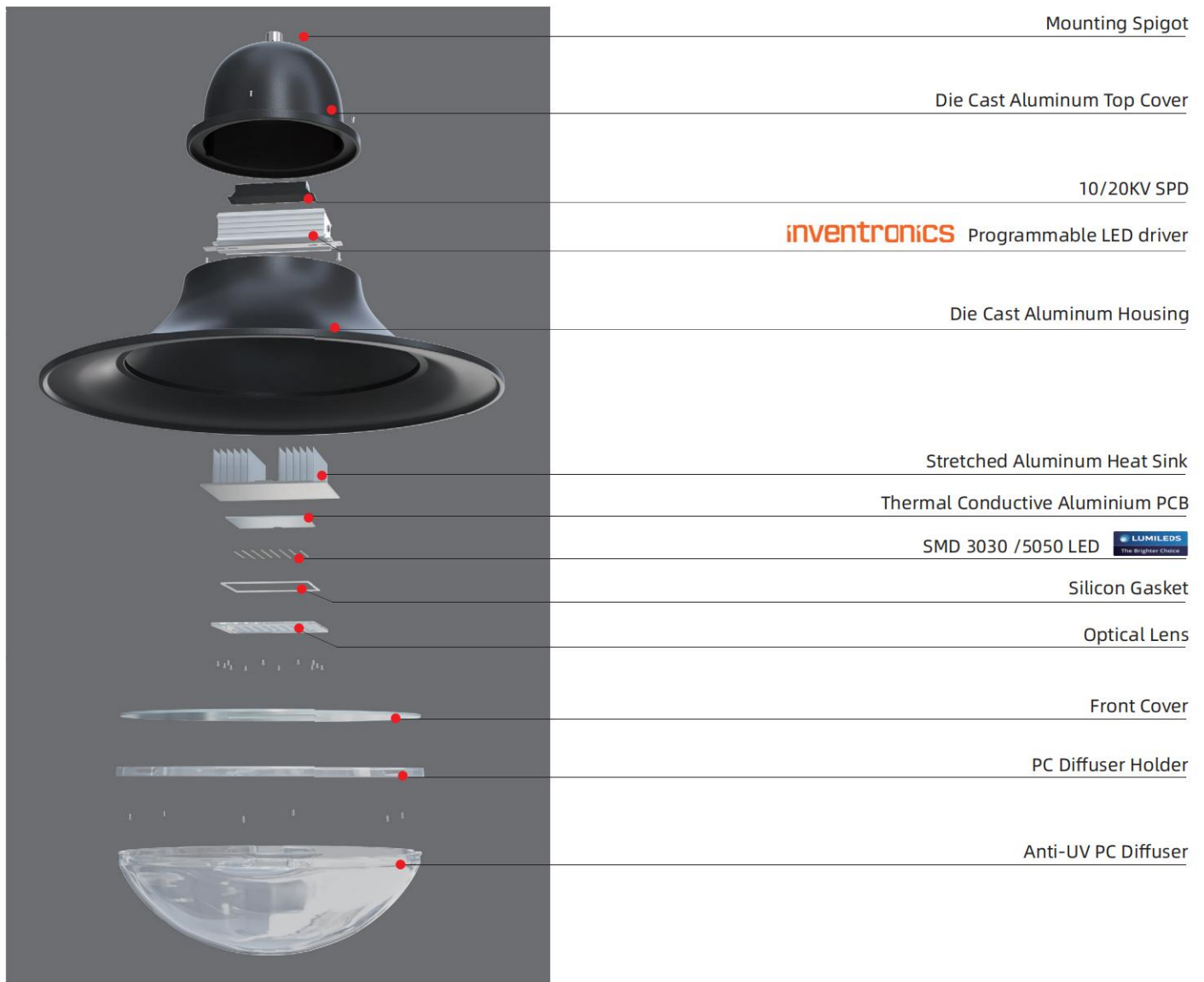

Dimension(mm)

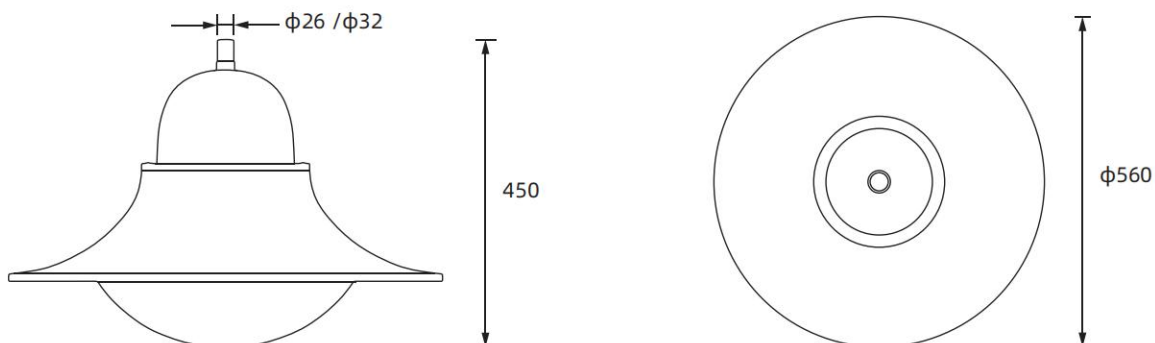

Light Distributions

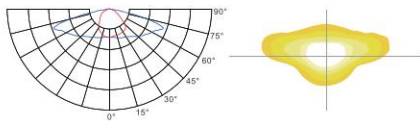

Type I 30x150

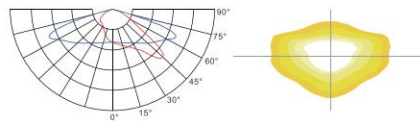

Type II 45X140

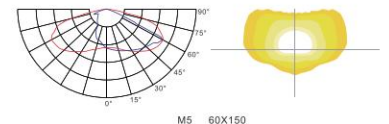

M5 60X150

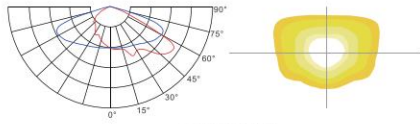

Type III 58X130

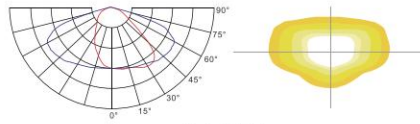

Ver B 35X140

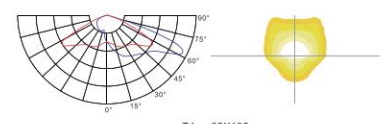

T4 65X135

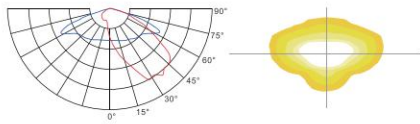

M1 45X130

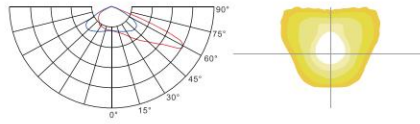

M6 60X135

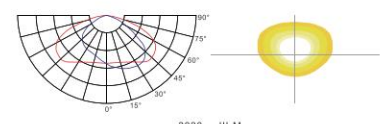

3030 III-M

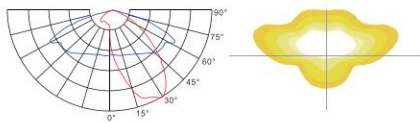

R3 25X140

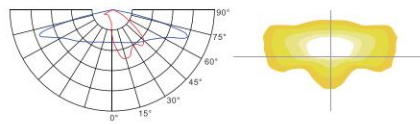

P4 20X145

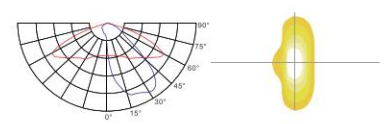

M2 30X130

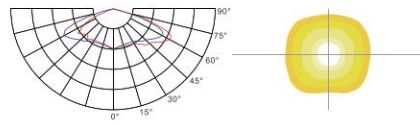

Type V 130X130

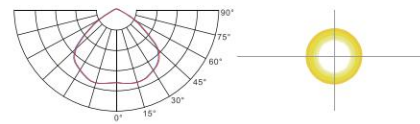

V90 90X90

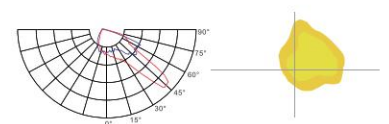

PR

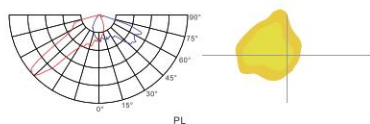

PL

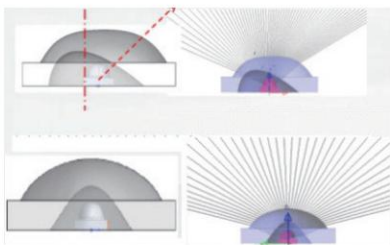

Asymmetric  
Optics

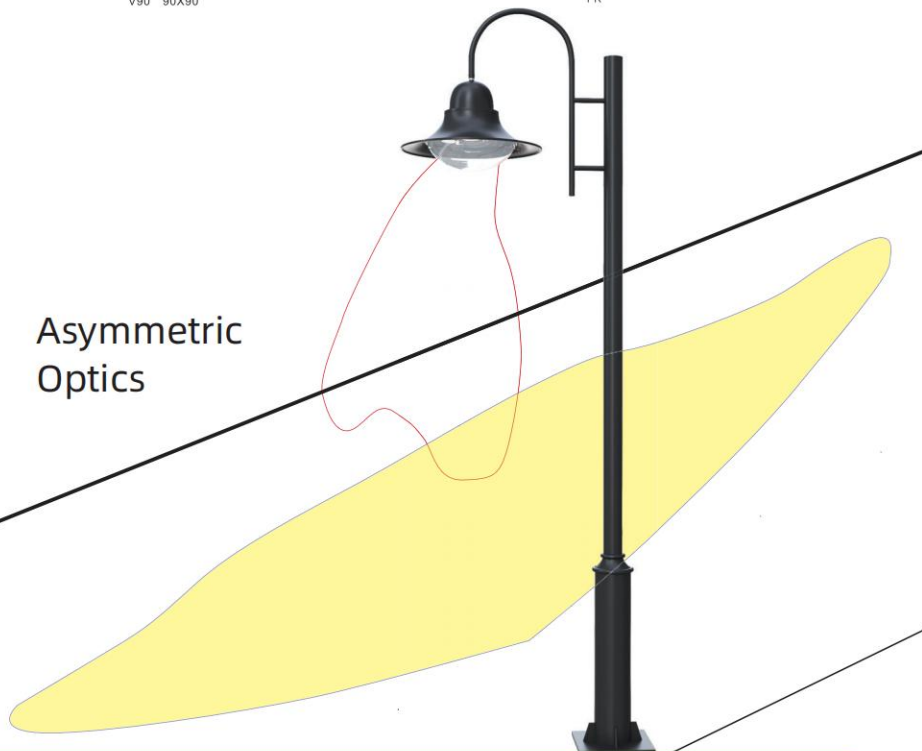



## SUGGESTED INSTALLATION HEIGHT



## CHARACTERS

Power	30W	40W	50W	60W
Protection Class	CLASS I/II			
IP/IK Rating	IP66, IK08			
Color Temperature	2200K-6500K	2200K-6500K	2200K-6500K	2200K-6500K
Efficiency	130 LM/W	130 LM/W	130 LM/W	130 LM/W
CRI	70/80	70/80	70/80	70/80
Input Voltage	AC 90-305V/347V/480V, 50/60Hz			
Driver Suggest	INVENTRONICS EBS, INVENTRONICS EUM			
Dimming	1-10V Dimming (Default) /Timer Dimming			
Surge Recommendation	10KV (Default) / 20KV (available on request)			
LED Type	LUMILEDS SMD LED			
LED Quantities 3030	48	64	80	96
Pcb Input Current (3030)	48V 540mA	48V 740mA	48V 920mA	96V 680mA
Mounting	Suspending with installation spigot dia 26mm/32mm			
Material	Die casting with standard adc12 type aluminum, stainless 314 clips and screws. Clear polycarbonate with uv-resistant acrylic. Option for screen for asymmetrical light.			
Painting Color Suggest	RAL9005 Jet Black /Other Colors on request			
Available on request	Motion Sensor, NTC, OLC, DALI Dimming, Smart Controller			
Weight	Net weight: 6kgs   Gross weight: 7kgs			
Packing Size	580x580x480mm			