

# LED STREET LIGHTS

## INSTALLATION INSTRUCTIONS

### IMPORTANT SAFEGUARDS

When using electrical equipment, basic safety precautions should always be followed including the following:

### READ AND FOLLOW ALL SAFETY INSTRUCTIONS

1. To avoid the possibility of electrical shock, turn off power supply before installation or servicing. Installation and servicing should be performed by qualified personnel.
2. When closing cover of fixture, be sure all wires are inside housing to avoid pinching wires.
3. If Photo Receptacle is installed refer to "Photo Control" section for Product must be installed in accordance with your local electrical code.
4. If you are not familiar with these codes and requirements, consult a qualified electrician
5. Do not change the structure or any components of the fixture to ensure safety.

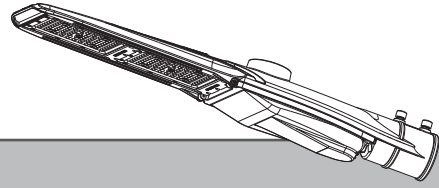

100-240V/277V AC, 50/60Hz, Suitable for Wet Locations (IP66), Class I

\*Only suit for outdoor use. Max installation height: 15M.

\*Normal operating position is on a mast arm or post top .

Pole fitter diameter:  $\Phi$  60mm (2.4") / \*48mm diameter need longer screws

\*This product must be grounding

Power	Dimension	EPA	Weight
60W	717 x178 x99 mm	0.153 m <sup>2</sup>	3.62 kg
70W	717 x178 x99 mm	0.153 m <sup>2</sup>	3.62 kg
80W	717 x178 x99 mm	0.153 m <sup>2</sup>	3.62 kg
90W	717 x178 x99 mm	0.153 m <sup>2</sup>	3.62 kg
100W	717 x178 x99 mm	0.153 m <sup>2</sup>	3.62 kg
110W	717 x178 x99 mm	0.153 m <sup>2</sup>	3.84 kg
120W	717 x178 x99 mm	0.153 m <sup>2</sup>	3.84 kg
130W	717 x178 x99 mm	0.153 m <sup>2</sup>	3.84 kg

### SAVE THIS INSTRUCTIONS FOR FUTURE REFERENCE

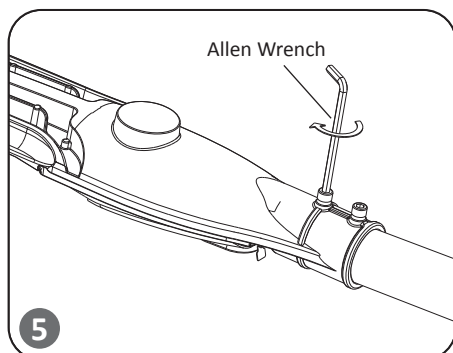
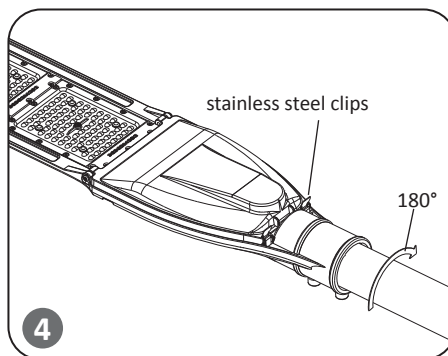
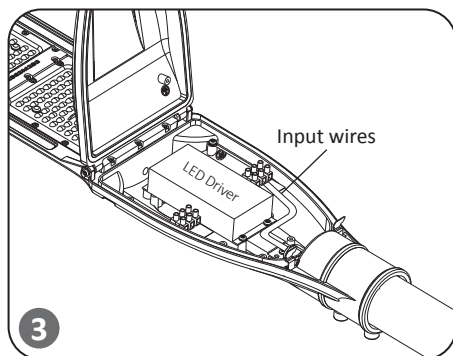
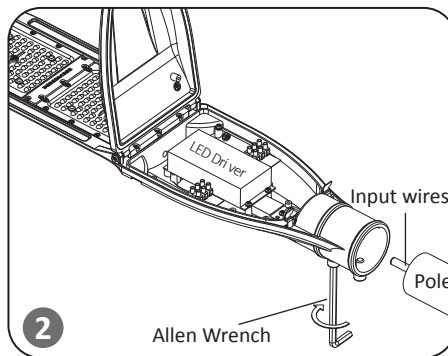
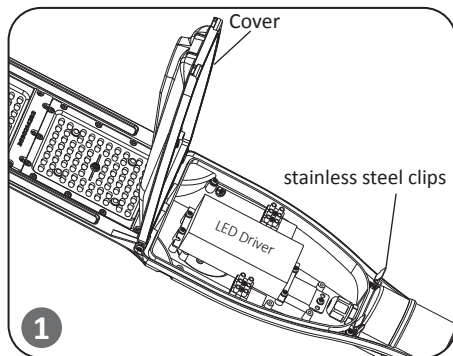

Allen Wrench: 8mm  
Inner Hexagon Screw: M10X25

### STANDARD MOUNTED

#### STEP 1:

Push the stainless steel clips to open the cover of driver box by hands.

#### STEP 2:

Loosen the two screws by 8mm allen wrench. Insert the power cord into the driver box and then insert the pole to the luminaire. Ensure the light-emitting area face up.

#### STEP 3:

Connect the wires into the terminal block. Adjust the length of wires and then fix the water-proof connector.

#### STEP 4:

Close the cover by hands, ensure the cover get stuck by the stainless steel clips . Rotate the luminaire by 180 degrees. Ensure the light-emitting area face down.

#### STEP 5:

Fix the luminaire on the pole by 8mm allen wrench.

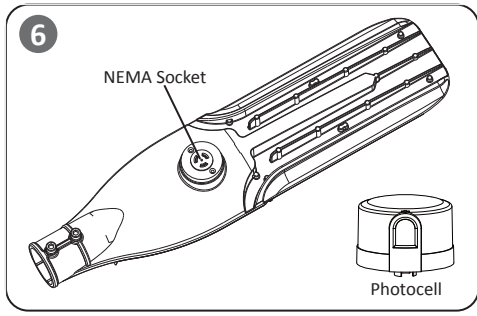

## PHOTO CONTROL (OPTIONAL)

If the fixture with PHOTO CONTROL function, the Photo Receptacle will be installed on the cover of fixture. See 6. Fit the pins of Photo Sensor to Photo Receptacle, firmly insert and rotate Photo Sensor to proper position.

<Verifying>

Make sure all the connections done and photo control is well installed on the fixture, switch on the power supply and cover the window of photo sensor, wait 5 seconds, the fixture will be turned on.

### IMPORTANT

Check whether it concerns an AC(Alternating Current) based or DC(Direct Current) based system.

## ELECTRICAL CONNECTIONS - 100-240V/277V AC, 50/60Hz

## Class I BASED

### STEP 1:

Make the following Electrical Connections:

- Connect **INPUT GROUND** conductor to "G" position of the terminal block.
- Connect **INPUT VOLTAGE** conductor to "L" position of the terminal block.
- Connect **INPUT NEUTRAL** conductor to "N" position of the terminal block.

### STEP 2:

Make sure all excess input wires are pushed into pole, screws are tightened.

### STEP 3:

Close cover by firmly pushing cover towards fixture, making sure that no wires are pinched and Sealing gasket are fully engaged.

### STEP 4:

If the fixture without a surge protector, please insulate all electrical connections with wire nuts suitable for at least 90°C.

Input cable should be at least H05RN-F 3x1.0mm<sup>2</sup>(SJTW 18AWG) or outdoor grade cable with rubber sheathed(not supplied). The cable must have a minimum cross sectional area of 1.0mm<sup>2</sup>(18AWG).

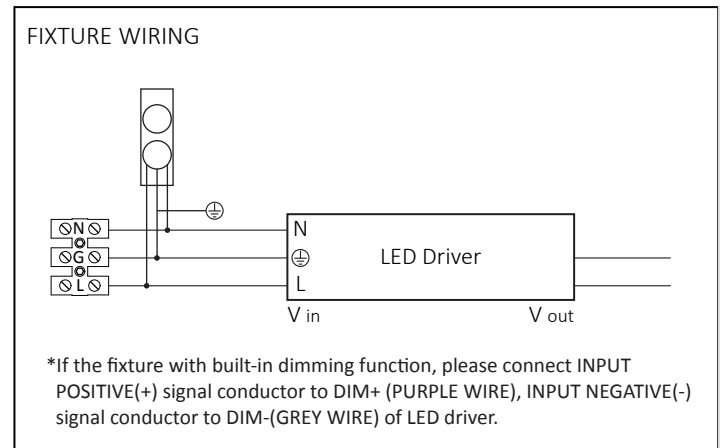

## ELECTRICAL CONNECTIONS - 100-240V/277V AC, 50/60Hz

## Class II BASED

### STEP 1:

Make the following Electrical Connections:

- Connect **INPUT VOLTAGE** conductor to "L" position of the terminal block.
- Connect **INPUT NEUTRAL** conductor to "N" position of the terminal block.

### STEP 2:

Make sure all excess input wires are pushed into pole, screws are tightened.

### STEP 3:

Close cover by firmly pushing cover towards fixture, making sure that no wires are pinched and Sealing gasket are fully engaged.

### STEP 4:

If the fixture without a surge protector, please insulate all electrical connections with wire nuts suitable for at least 90°C

Input cable should be at least H05RN-F 3x1.0mm<sup>2</sup>(SJTW 18AWG) or outdoor grade cable with rubber sheathed(not supplied). The cable must have a minimum cross sectional area of 1.0mm<sup>2</sup>(18AWG).

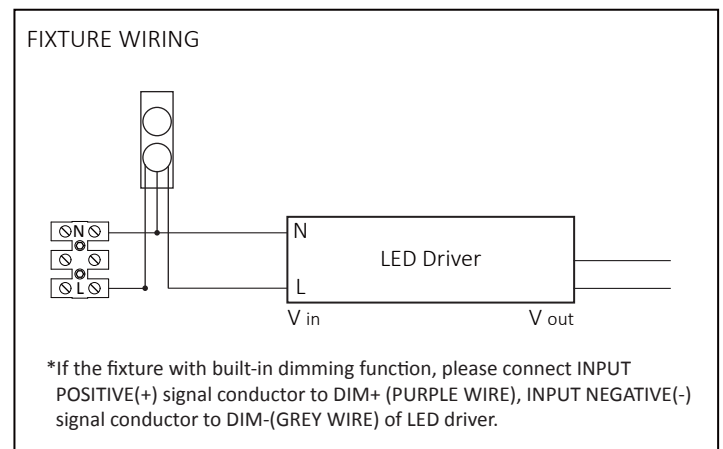

This marking indicates that this product should not be disposed with other household wastes throughout the EU. To prevent possible harm to the environment or human health from uncontrolled waste disposal, recycle it responsibly to promote the sustainable reuse of material resources. To return your used device, please use the return and collection systems or contact the retailer where the product was purchased. They can take this product for environmental safe recycling.